

The logo for KETA I, featuring the brand name in a bold, orange, sans-serif font with a registered trademark symbol.

## SMRITI G2

SMRITI G2 is updated with integrated driver and better design for heat dissipation to ensure a longer lifespan of five years. The lamp has reflector and lens version for option. MHT8959 takes high efficiency and excellent UGR into accounts.



## Aluminum advantages:

**1**

High reflectivity, up to 95-98%, and 8-10% higher than conventional with spinning processing

**2**

Reducing environment pollution by using high quality of aluminium material so that there is no need for the secondary treatment on the surface.

**3**

Excellent resistance to high temperature to keep this reflector for long lifespan and good appearance without color change. 5 years for antioxidation and anti-fading.

# SMRITI G2



## Control Type



## Luminaire specifications

Mode	Power	Lumen	CCT	BA.	Light Source	Driver	CRI
MHT8958	20W	1932	3000K	15/24/36/60°	Bridgelxu	TRIDONIC	90
MHT8959	28W	2762	3000K	15/24/36/60°	Bridgelxu	TRIDONIC	90
MHR8959(High)	28W	3770	3000K	15/24/30/45/60°	LUMINUS	TRIDONIC	90
MHT8960	40W	3681	3000K	15/24/36/60°	Bridgelxu	TRIDONIC	90
MHT8958A	20W	1911	3000K	16/24/40/60°	Bridgelxu	TRIDONIC	90
MHT8959A	28W	2609	3000K	16/24/40/60°	Bridgelxu	TRIDONIC	90
MHT8959A(High)	28W	3887	3000K	17/30/45/60°	LUMINUS	VS	90
MHT8960A	40W	3512	3000K	16/24/40/60°	Bridgelxu	TRIDONIC	90

All values are measured at 220V(+/- 10%).  
 Color temperature range 2700K/3000K/3500K/4000K/5000K/6000K/Tunable White.  
 Colour Rendering Index (CRI) CRI80, CRI90  
 Die-casting Aluminum

## Frame Finishing color

- Black RAL9005
- Grey RAL9006
- White RAL9016

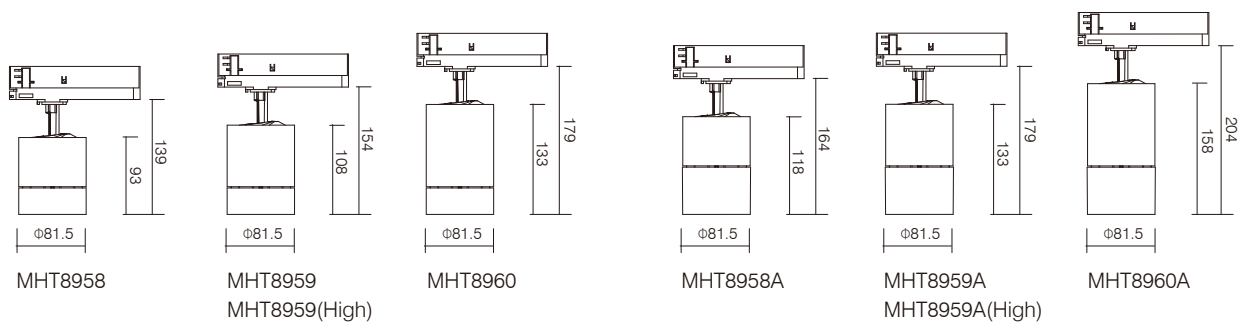

# SMRITI G2

MHT8958, 20W, 1932LUM

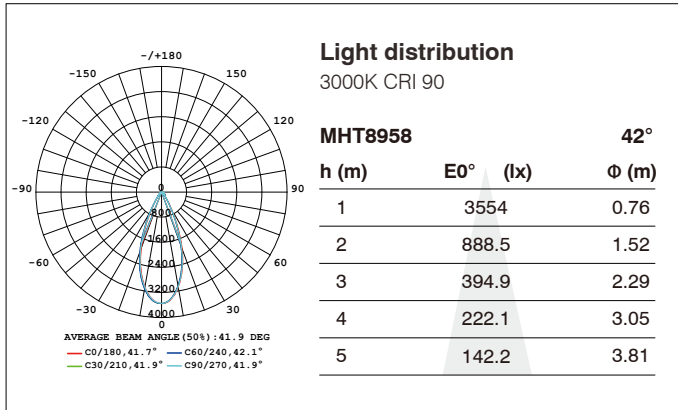

MHT8959, 28W, 2762LUM

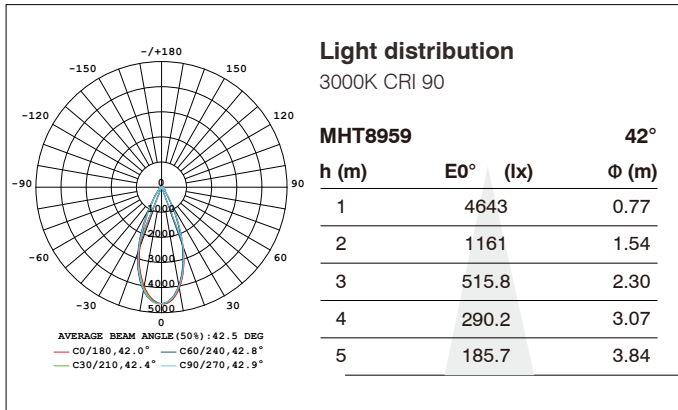

MHT8959(High), 28W, 3770LUM

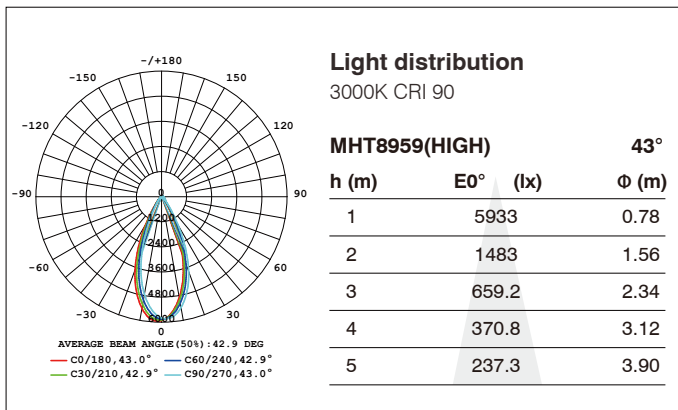

MHT8960, 40W, 3681LUM

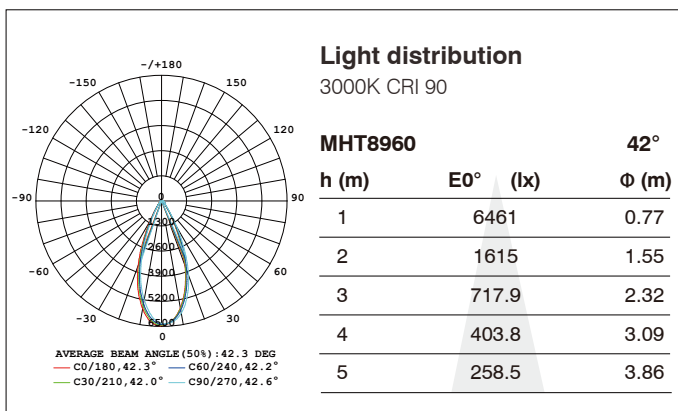

### MHT8958A, 20W, 1911LUM

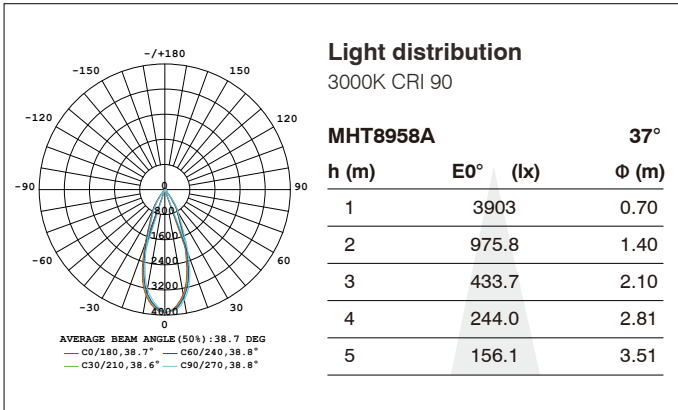

### MHT8959A, 28W, 2609LUM

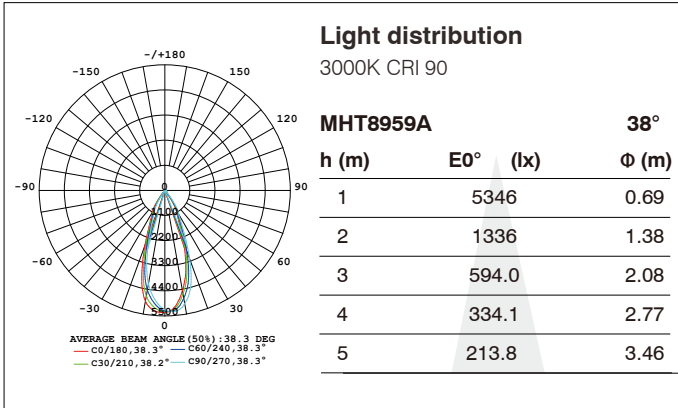

### MHT8959A(High), 28W, 3887LUM

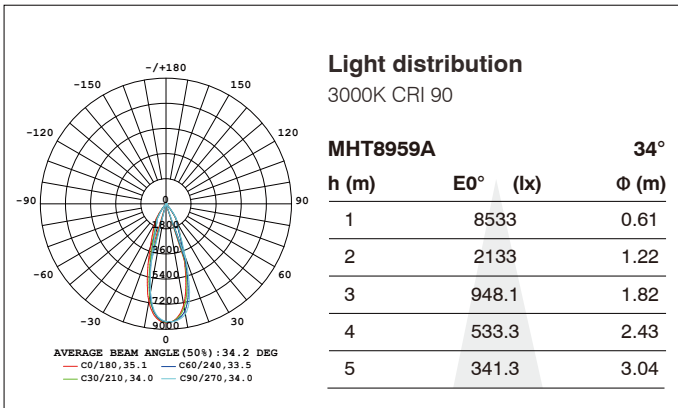

### MHT8960A, 40W, 3512LUM

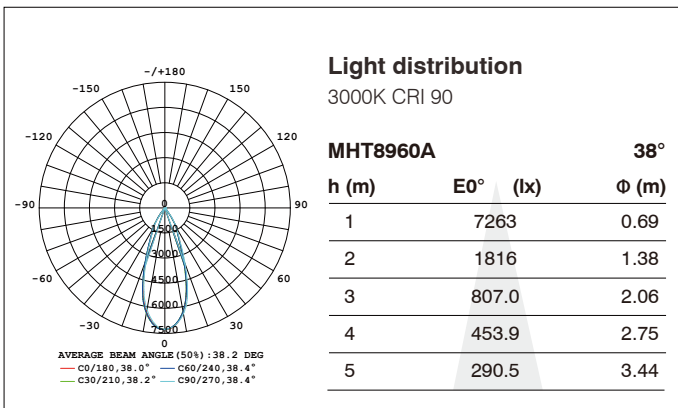



KETAI INDUSTRIES LIGHTING CO.,LTD.  
Ketai Building, 4 Mashe New Street, Lishui, Nanhai,  
Foshan Guangdong, China  
T : +86 757 8560 7707  
F : +86 757 8563 3675  
E : sales@ketailighting.com

Join Us!

[www.ketailighting.com](http://www.ketailighting.com)

**KETAI**<sup>®</sup>